



MECHANICAL SEQUENCER CAMS & GAUGES

Minimatic® Cams



Minimatic Sequence Programmer Cams. Use with Clippard MSP or DSP sequence programmers.

Available in 8 models pre-cut with lobes from 15° to 340°, also blank 360° cam for custom machining.

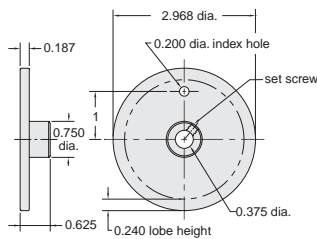

Order No.	Lobe	Order No.	Lobe
C-33-15	...15°	C-33-180	...180°
C-33-30	...30°	C-33-270	...270°
C-33-60	...60°	C-33-340	...340°
C-33-90	...90°	C-33-360	...uncut*
C-33-120	...120°		

Adjustable Cams



Use with Clippard MSP or DSP sequence programmers. Available in five models with adjustable lobes covering from 30° to 360°, also as a blank for custom machining.

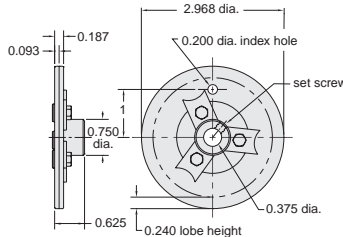

Order No.	Lobe Adjustment	
	From	To
A-33-30	...30°	...50°
A-33-45	...45°	...80°
A-33-70	...70°	...130°
A-33-120	...120°	...230°
A-33-210	...210°	...360°
A-33-360	...uncut	

Detent Cams



One standard phenolic detent cam with 4, 6, 8, 10 or 12 evenly spaced cuts is required with each DSP. Special cut detent cams are available at nominal cost.

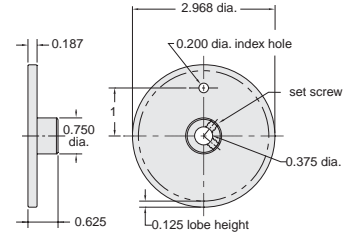

Order No.	Number of Positions
DC-4	...4
DC-6	...6
DC-8	...8
DC-10	...10
DC-12	...12

Vacuum Gauge

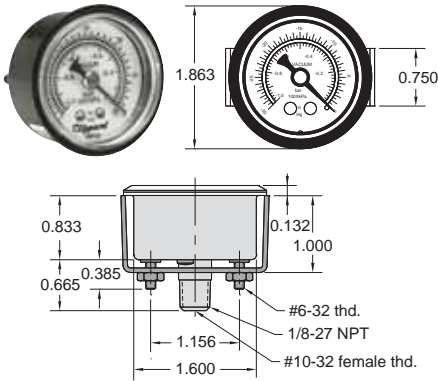

Gauge measures pneumatic vacuum pressure. Mounting bracket included.

Range: Scale reading from 0 to 30 in.Hg. and 0 to -1 bar

Construction: Nickel-plated steel case. Plastic face. Dial shows two ranges; Hg in black. Bars in red. Built-in pressure snubber.

Ports: Connection located at rear is double threaded O.D. - male thread 1/8" NPT I.D. - tapped for #10-32 fitting

Mounting: Stud mount using 1/8" NPT center stud or panel mount using the zinc plated steel bracket supplied.

Part No.	Description
VG-30	...Vacuum Gauge

Pressure Gauge

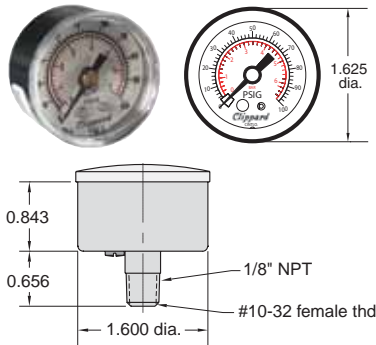

Gauge measures pneumatic system pressure. Stud mounted.

Range: Scale reading from 0 to 100 psig and 0 to 6.9 bar

Construction: Steel case. Plastic face. Dial shows two ranges; psig in black. Bars in red. Built-in pressure snubber.

Ports: Connection located at rear is double threaded O.D. - male thread 1/8" NPT I.D. - tapped for #10-32 fitting

Mounting: Direct with 1/8" NPT

Part No.	Description
PG-101-BK	...Pressure Gauge, Black Case
PG-101-NP	...Pressure Gauge, Nickel-Plated

Pressure Gauge

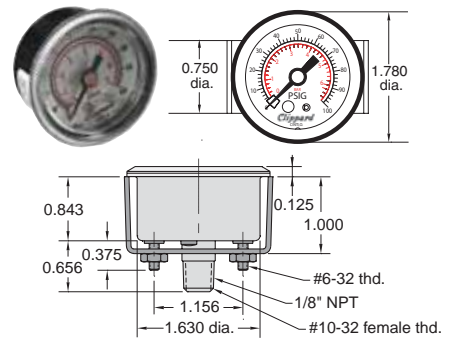

Gauge measures pneumatic system pressure. Mounting bracket included.

Input Pressure: Scale reading from 0 to 100 psig and 0 to 6.9 bar

Construction: Nickel-plated steel case. Plastic face. Dial shows two ranges; psig in black. Bars in red. Built-in pressure snubber.

Ports: Connection located at rear is double threaded O.D. - male thread 1/8" NPT I.D. - tapped for #10-32 fitting

Mounting: With zinc plated steel bracket supplied

Part No.	Description
PG-100	...Pressure Gauge